

Clantrac®

STRONG-ARM



HYDRAULIC MOTORCYCLE LIFT

MODEL NO: CML3, CML3AIR

PART NO: 7610143, 7610144

OPERATION & MAINTENANCE INSTRUCTIONS



ORIGINAL INSTRUCTIONS

DL 0922 ISS 7

INTRODUCTION

Thank you for purchasing this CLARKE hydraulic motorcycle lift.

Before attempting to operate this product, it is essential that you read this manual thoroughly and carefully follow all instructions given. In doing so you can look forward to the product giving you long and satisfactory service.

GUARANTEE

This CLARKE product is guaranteed against faulty manufacture for a period of 12 months from the date of purchase. Please keep your receipt as proof of purchase.

This guarantee is invalid if the product is found to have been abused or tampered with in any way, or not used for the purpose for which it was intended.

Faulty goods should be returned to their place of purchase, no product can be returned to us without prior permission.

This guarantee does not effect your statutory rights.

SPECIFICATIONS

Model Number	CML3 & CML3AIR
Maximum Load	450 kg
Minimum Table Height	130 mm
Maximum Table Height	770 mm (excl wheel clamp)
Net weight inc wheel clamp	139kg (CML3) 145 kg (CML3A)
Table length	2200 mm
Table length with ramp	2790 mm
Operating air pressure (Air version only)	120-200 psi (8.27-13.78 bar)
Operating temperature range	4°C - 40°C

SAFETY PRECAUTIONS

1. **NEVER** exceed the safe working load of 450 kg and only use the motorcycle lift for its intended purpose.
2. **NEVER** use the lift if it has been subjected to an abnormal load or shock. It should be removed from service immediately and fully inspected by qualified personnel before being passed as serviceable before being used again.
3. **NEVER** rely on the hydraulic ram to support the table when loaded. Always use the locking bar to hold the table in one of the two positions provided.
4. **NEVER** crawl or reach under the platform unless it is mechanically locked using the safety bar provided.
5. **ALWAYS** use the lift on a solid, flat, level surface.
6. **ALWAYS** screw down the stabilisers before putting the table under load.

NOTE: *The castors are not designed to take the weight of the motorcycle but are used merely to move the lift quickly and easily around the workshop. On no account must you raise a loaded platform unless the stabilisers are screwed down, and NEVER use the lift to transport a load.*

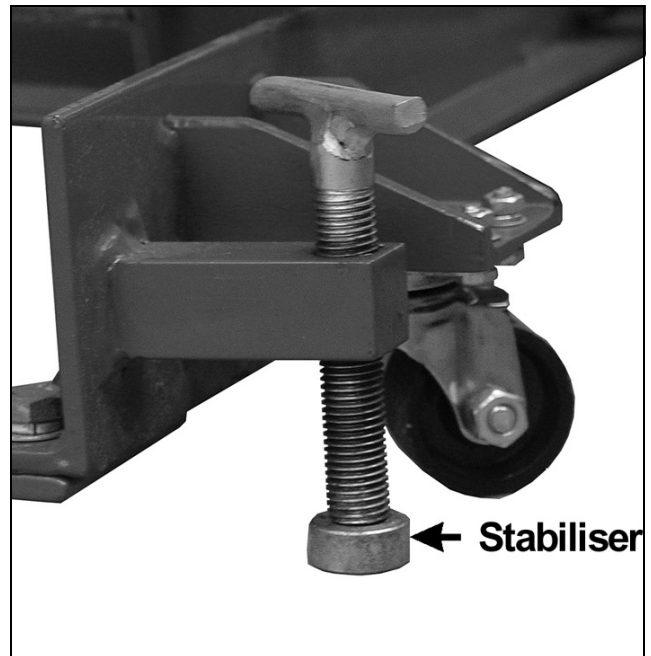

7. **ALWAYS** use appropriate safety equipment such as protective footwear when using this lift.
8. **ALWAYS** inspect the lift before use to ensure it is in good condition and replace any damaged or worn parts.
9. **ALWAYS** use spare parts supplied by Clarke International. Using non-standard parts could be extremely dangerous.
10. **ENSURE** the operator is trained in both operational and safety aspects of using this product.
11. **NEVER** leave this lift unattended whilst there is a load on it.
12. **NEVER** allow children or bystanders anywhere near this lift whilst it is in use.

ASSEMBLY & PREPARATION

Check to ensure that no damage has occurred during transit. Any damage should be reported to your Clarke dealer immediately.

Using a clean, level area, unpack the equipment, laying out the loose items.

The motorcycle lift is packed flat in its lowest position. It is fully assembled, except for ancillary items which are fitted as follows.

1. Attach the largest foot lever, (A), to its square spigot on the base of the unit, with the foot pedal facing upwards and set at approximately 10 o'clock - looking side on.
2. Attach the lowering pedal (B) in the manner shown in Fig.2.
3. Attach the safety plate (C), using the nuts, bolts and washers provided. This plate is essential to prevent accidental contact with the lowering pedal which could result in unexpected lowering of the table.

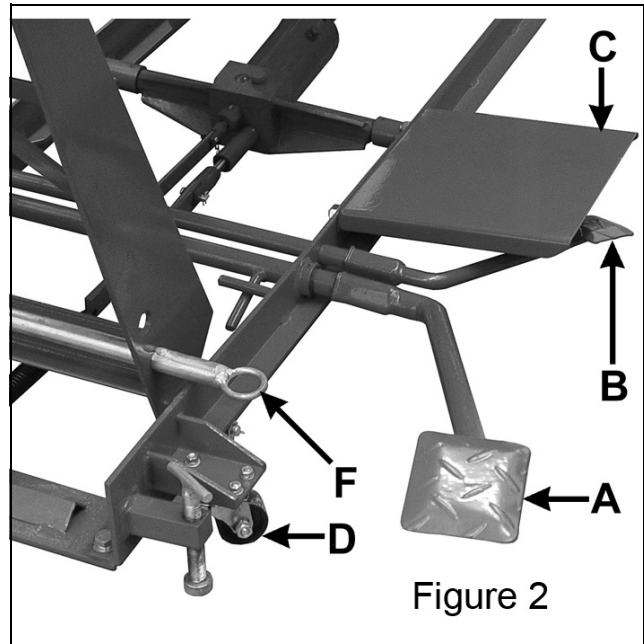

4. Attach the two castors (D), securing with the nuts bolts and washers provided.
5. Attach the ramp (E) by dropping the lugs into the holes in the table and securing with the 'R' clips provided.
6. **CML3** - Pump the foot pedal very gently to begin with, to ensure that all parts are free. Continue to pump the pedal and observe the table rising. If any resistance is felt, investigate to ensure that no part is jammed by a loose or stray ancillary component.

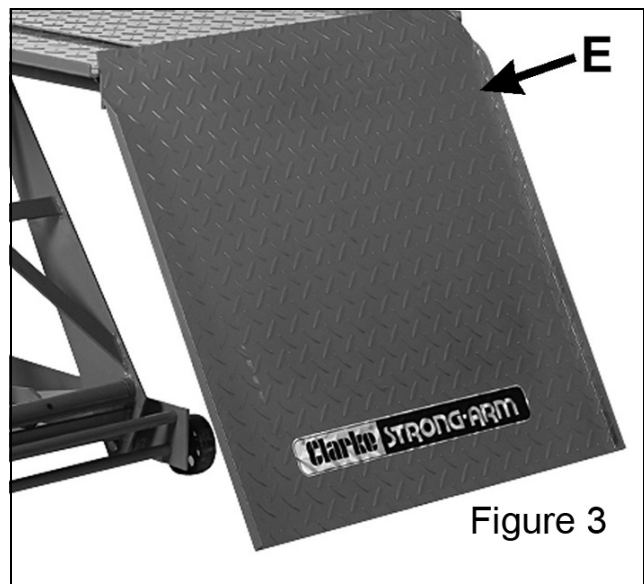

7. When the table is at its full height, it should be possible to insert the locking bar (F), through the hole in the frame, (adjacent to the castor mounting bracket), the corresponding holes in each side of the front lifting arm and out through the opposite side of the frame.

- The locking bar secures the table to prevent any possibility of it lowering while working, and to provide a table working platform.

8. Press the lowering lever (B) so that the weight of the table is taken by the locking bar.

9. Attach the front wheel clamps (G & H) and stop Plate (J) in the manner shown in Fig.4.

10. Attach the lashing eyes (K), - one to each side as shown in Fig. 4. The lift is now fully assembled.

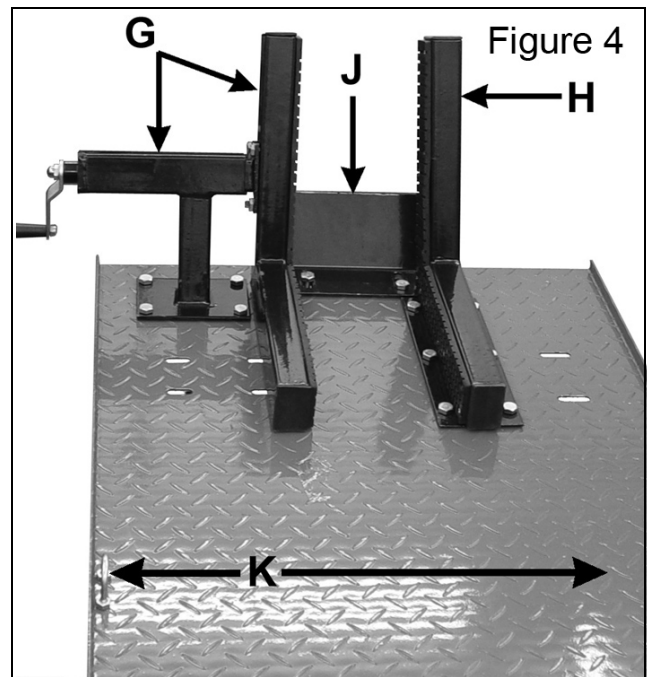

CML3AIR

1. Using all safety precautions with regard to using air equipment - (REFER TO THE AIR COMPRESSOR MANUAL), connect a suitable air hose equipped with a snap on type connector to the hand controller shown in Fig. 5.

- The hand controller is located on the end of the hose leading to the hydraulic ram.

2. Start the compressor with the outlet pressure set to zero and then open the outlet valve.

3. Set the output pressure to between 8 - 13 bar, depending upon the compressor size.

4. Press down the operating lever of the hand controller. The ram will begin to operate and the platform will rise. Be prepared to release the lever immediately should any part of the lift become snagged.

5. Raise the platform to its maximum height, then proceed as described in para. 7.

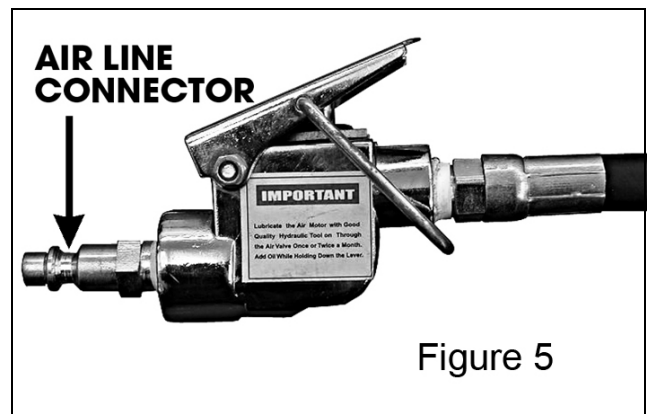

NOTE: A 1HP (MIN) air compressor is recommended for operation, although a 2HP compressor will increase the speed of operation.

FURTHER ASSEMBLY

When the pedal is assembled you may find that the foot plate is too near the bottom of the safety plate. If so make these adjustments.

1. Raise the table and engage the safety locking bar as described on page 5 point 7.
2. When the table is secure, identify the adaptor, pin and 'R' clip as shown above.

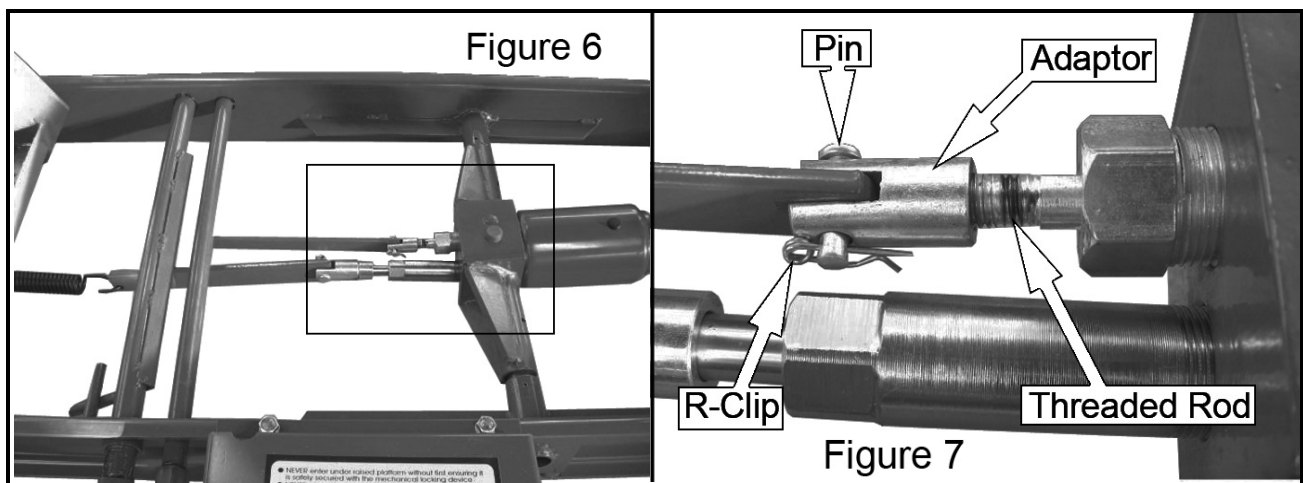

3. Remove the 'R' clip and pin and let the link bar drop down from between the flanges of the adaptor.
4. Loosen the adaptor from the threaded pin by 2 - 3 threads.
5. Refit the link bar using the pin and 'R' clip'.
6. The foot plate should have lowered in relation to the pedal guard.
7. If the necessary foot plate position has not been reached, Repeat the operation (Do not loosen the adaptor too much, make sure that sufficient thread engages with the pin).

SYSTEM AIR PURGE

In the event of the platform not pumping up to full height it may be necessary to purge air from the hydraulic system.

1. Pump up the platform as far as possible then fully lower using the lowering pedal.

2. Remove the filler plug to release any trapped air, top up the reservoir with clean hydraulic fluid and re-insert the plug.
3. Repeat operations 1 and 2 (above) until all air is purged from the system.

If the above procedure does not cure the fault contact your local Clarke dealer.

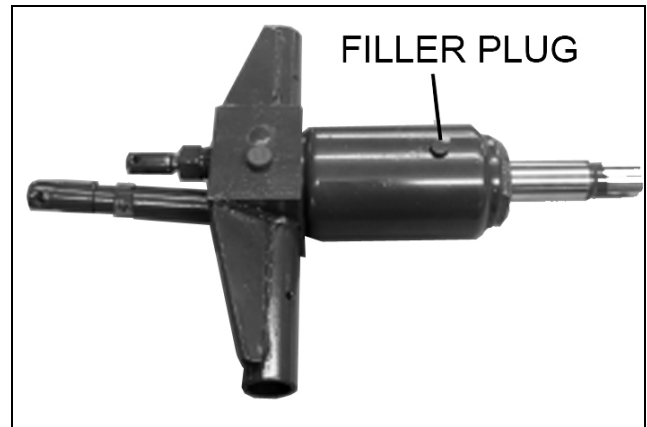

TO LOWER THE LIFT

As the weight of the table is taken by the Locking Bar, it is necessary to pump the Foot Lever slightly in order to take the strain and then remove the Locking Bar.

1. Visually check under and around the lift to ensure that no obstruction will interfere when lowering the table.
2. Depress the lowering lever until the table is at its lowest position.
3. To manoeuvre the lift around the workshop, screw up the stabilizers to allow the castors to function. For storage purposes, always screw the stabilizers down to take the weight off the castors.

OPERATION

Always carry out a visual check before use to ensure the lift is serviceable, never take things for granted.

For safety purposes, loading the lift is essentially a two man operation.

DO NOT exceed the maximum lifting capacity of 450kg (1000lbs)

UNDER NO CIRCUMSTANCES should you ride a motorcycle on to the lift, and on no account allow anyone to mount the motorcycle whilst it is on the table.

With the lift maneuvered to a suitable position which allows adequate working space, screw down the stabilizers in order to take the weight off the casters and to prevent any possible movement of the table whilst working.

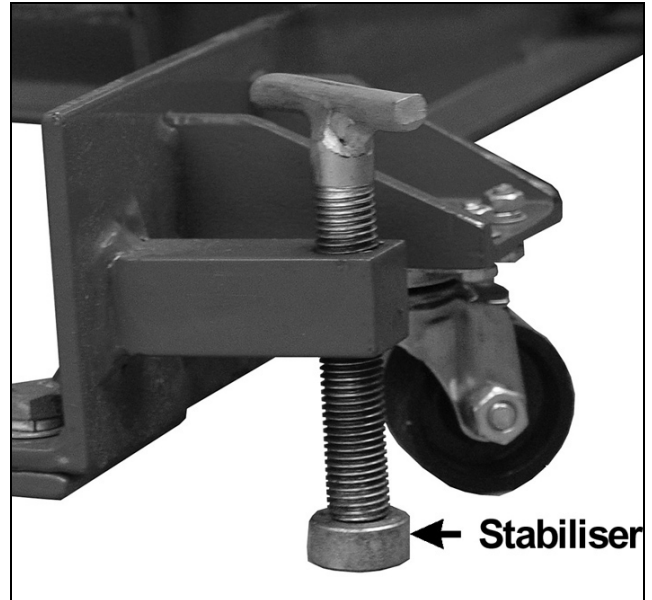

With the wheel clamp wide open, lower the table to its lowest position and with one person either side of the motorcycle, position it on the table so that the front wheel rests up against the stop plate.

Wind in the moveable wheel clamp to secure the front wheel and tighten.

Secure the motorcycle with straps using the lashing eyes, one each side of the table.

Before raising the table, check to ensure the motorcycle is perfectly stable.

Ensuring there is nothing to obstruct the table, press the raising lever repeatedly, or use the air controller if fitted, and raise to an appropriate height to insert the safety bar.

NOTE: Two positions are provided into which the safety bar may be inserted, giving two working heights.

With the safety bar correctly inserted, lower the table using the lowering foot lever to ensure the full weight of the table is taken by the safety bar.

If the rear wheel is to be removed, ensure the motorcycle rests on its centre stand and is well lashed down. Alternatively, a 'Paddock Stand' may be used to raise and secure the trailing axle. The cover of the opening, at the rear of the table, may be removed to facilitate the removal of the rear wheel.



WARNING: ENSURE THE FOLLOWING BEFORE COMMENCING WORK ON THE MOTORCYCLE:

- The safety bar is inserted and the table lowered so that the safety bar is taking the FULL weight of the table
- The motorcycle securely lashed.
- The stabilizers are screwed down to prevent the motorcycle lift from moving.

MAINTENANCE

1. Periodically check that all joints and pivots are clean and moving freely.
2. Lubricate all pivots and spindles with light oil using the oil holes provided.
3. Check the action of the hydraulic ram and inspect for leaks. If leaks are apparent, do not use the lift but carry out or submit for repair before use.
4. Visually inspect the lift for distortion of parts, cracked welds, damaged wheels or castors, oil leakage from the ram, or any other sign of damage. Should any of these be found, do not use the lift. Always have it inspected and repaired by a qualified technician before putting back into use. If necessary, consult your Clarke dealer.
5. If the warning label becomes illegible have it replaced. Contact your Clarke dealer.

PARTS LIST CML3

ITEM	DESCRIPTION
1	Hydraulic pump
2	Release valve rod
3	Pin
4	R-pin
5	Release valve pin
6	Pump rod
7	Pin
8	Pump location pin
9	Pin
10	Foot pedal (release)
11	Foot pedal (lifting)
12	Bolt
13	Washer
14	Castor
15	Bolt
16	Washer
17	Long sleeve
18	Support
19	Platform
20	Lock washer
21	Nut
22	Pin
23	Washer
24	Bolt
25	Lock washer
26	Nut
27	Spring
28	Short sleeve
29	Bolt
30	Nut

ITEM	DESCRIPTION
31	Cotter pin
32	Stop plate
33	Nut
34	Screw
35	Platform
36	Cover
37	Ramp
38	Slave arm
39	Main arm
40	Screw
41	Bolt
42	U-bolt
43	Washer
44	Steel wheel
45	Screw
46	Bottom frame
47	Set screw
48	Hinge pin
49	Active shaft
50	Fixed shaft
51	Rubber pad 1
52	Rubber pad 2
53	Rubber plug
54	Bolt
55	Winch assembly
56	Bolt
57	Lock washer
58	Washer
59	Plate

PART DIAGRAM

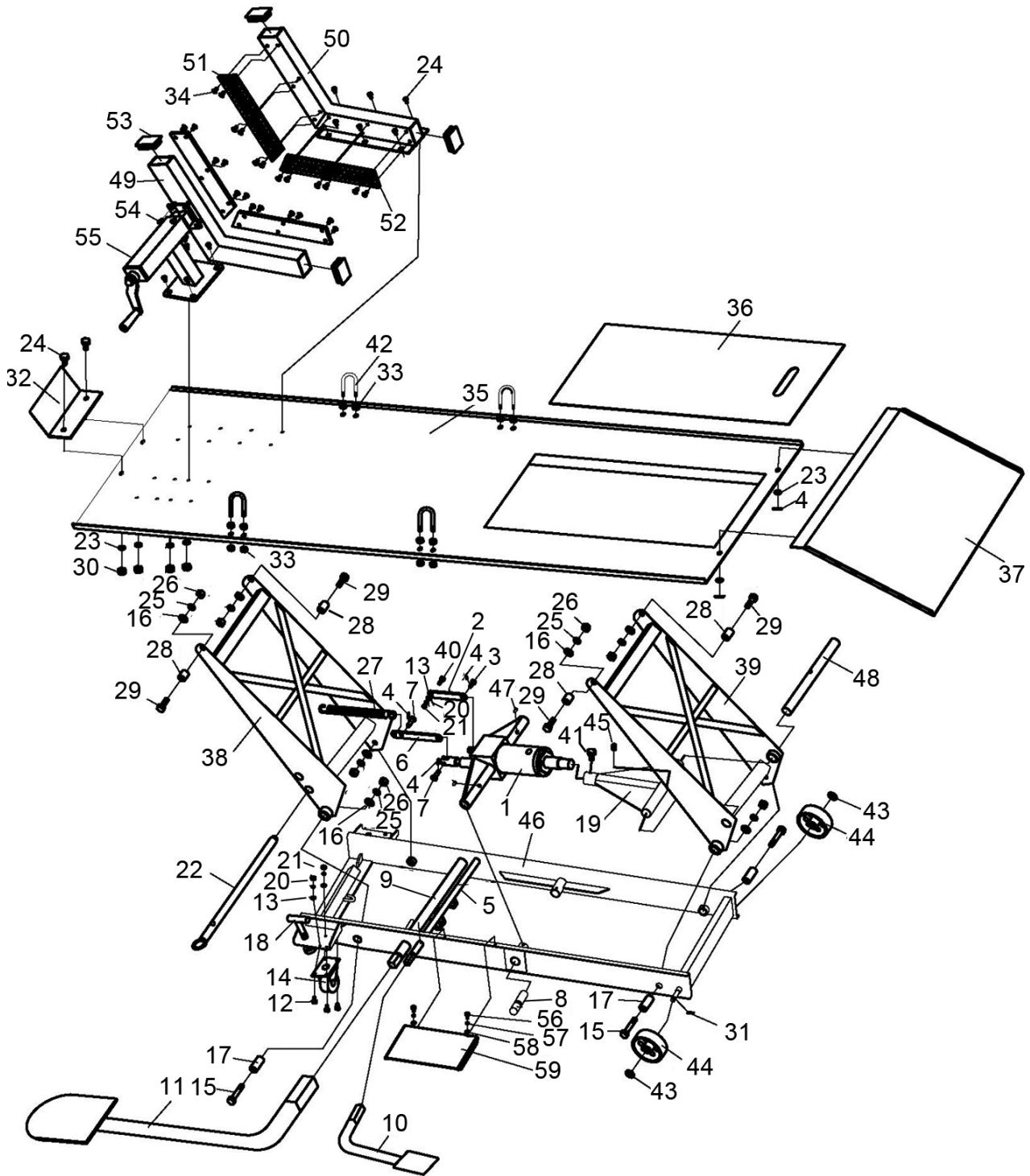

PARTS LIST CML3AIR

ITEM	DESCRIPTION
1	Hydraulic pump
2	Release valve rod
3	Pin
4	R-pin
5	Release valve hinge pin
6	Pump rod
7	Pin
8	Pump location pin
9	Bolt
10	Foot pedal (release)
11	Foot pedal (lifting)
12	Bolt
13	Washer
14	Castor
15	Bolt
16	Washer
17	Long sleeve
18	Support
19	Pump headplate
20	Lock washer
21	Nut
22	Hinge Rod
23	Washer
24	Bolt
25	Lock washer
26	Nut
27	Spring
28	Short sleeve
29	Bolt
30	Nut

ITEM	DESCRIPTION
31	Cotter pin
32	Stop plate
33	Nut
34	Screw
35	Platform
36	Cover panel
37	Ramp
38	Slave arm
39	Main arm
40	Screw
41	Bolt
42	U-bolt
43	Washer
44	Steel wheel
45	Grub Screw
46	Bottom frame
47	Set screw
48	Hinge pin
49	Active Arm
50	Fixed Arm
51	Rubber pad 1
52	Rubber pad 2
53	Rubber plug
54	Bolt
55	Winch assembly
56	Bolt
57	Lock washer
58	Washer
59	Circlip (large)
60	Circlip (small)

ITEM	DESCRIPTION
61	Hinge shaft
62	Air motor
63	Air hose assembly

ITEM	DESCRIPTION
64	Control valve
65	Airline coupling
66	Cross support

PART DIAGRAM-CML3AIR

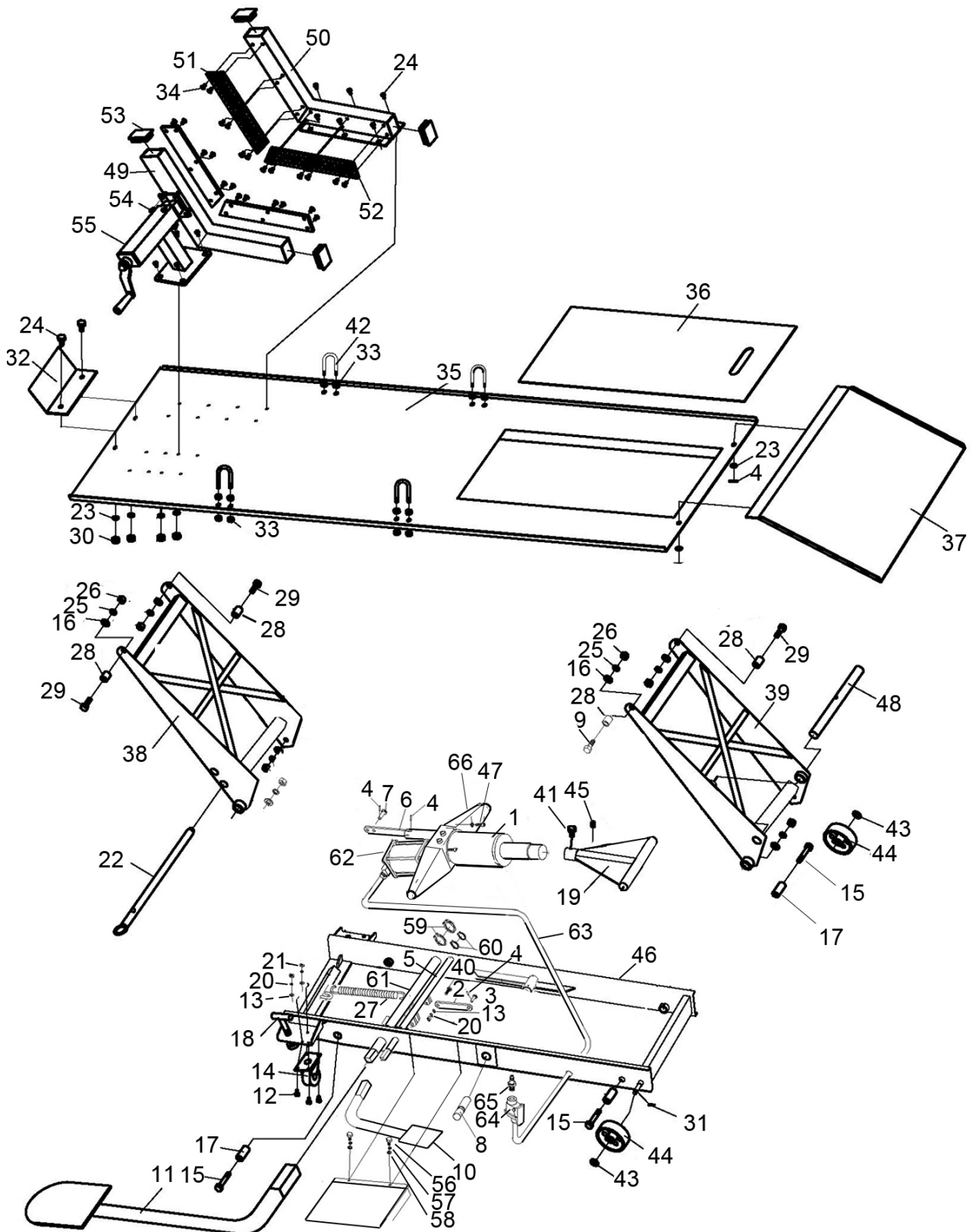

DECLARATION OF CONFORMITY



Hennell Street, Epping, Essex CM16 4LG

DECLARATION OF CONFORMITY

This is an important document and should be retained.

We hereby declare that this product(s) complies with the following statutory requirement(s):

Supply of Machinery (Safety) Regulations 2008

The following standards have been applied to the product(s):

EN 1493:2010, EN/ISO 12100:2010

The technical documentation required to demonstrate that the product(s) meet(s) the requirement(s) of the aforementioned legislation has been compiled and is available for inspection by the relevant enforcement authorities.

The UKCA mark was first applied in: 2022

Product Description: Motorcycle Lift

Model number(s): CML3

Serial / batch Number: N/A

Date of issue: 22/09/2022

Signed:

J.A. Clarke
Director



Fitzwilliam Hall, Fitzwilliam Place, Dublin 2

DECLARATION OF CONFORMITY

This is an important document and should be retained.

We hereby declare that this product(s) complies with the following directive(s):

2006/42/EC Machinery Directive

The following standards have been applied to the product(s):

EN 1493:2010, EN/ISO 12100:2010

The technical documentation required to demonstrate that the product(s) meet(s) the requirement(s) of the aforementioned directive(s) has been compiled and is available for inspection by the relevant enforcement authorities.

The CE mark was first applied in: 2010

Product Description: Motorcycle Lift

Model number(s): CML3

Serial / batch Number: N/A

Date of issue: 22/09/2022

Signed:

J.A. Clarke
Director

A SELECTION FROM THE VAST RANGE OF

Clarke®

QUALITY PRODUCTS



AIR COMPRESSORS
From DIY to industrial, Plus air tools, spray guns and accessories.

GENERATORS
Prime duty or emergency standby for business, home and leisure.

POWER WASHERS
Hot and cold, electric and engine driven - we have what you need

WELDERS
Mig, Arc, Tig and Spot. From DIY to auto/industrial.

METALWORKING
Drills, grinders and saws for DIY and professional use.

WOODWORKING
Saws, sanders, lathes, mortisers and dust extraction.

HYDRAULICS
Cranes, body repair kits, transmission jacks for all types of workshop use.

WATER PUMPS
Submersible, electric and engine driven for DIY, agriculture and industry.

POWERTOOLS
Angle grinders, cordless drill sets, saws and sanders.

STARTERS/CHARGERS
All sizes for car and commercial use.



PARTS & SERVICE: 0208 988 7400

Parts Enquiries
Parts@clarkeinternational.com

Servicing & Technical Enquiries
Service@clarkeinternational.com

SALES: UK 01992 565333 or Export 00 44 (0)1992 565335

Clarke® INTERNATIONAL Hemnall Street, Epping, Essex CM16 4LG
www.clarkeinternational.com